



Arm Take-off Sheet.

Machine Make:

Machine Model:

Stick Length:

Customer Name:

Completed by:

Date:

Comments/Special Instructions:

Arm Details.

Please fill in all brackets clearly.

Note:

Dimensions A, B and C are required to determine boom to stick angle. Mark equal points A and B, then measure distance C.

Boom Width

Width of Boom Plate
in this area

() (E)

(C)

Full Curl (D)

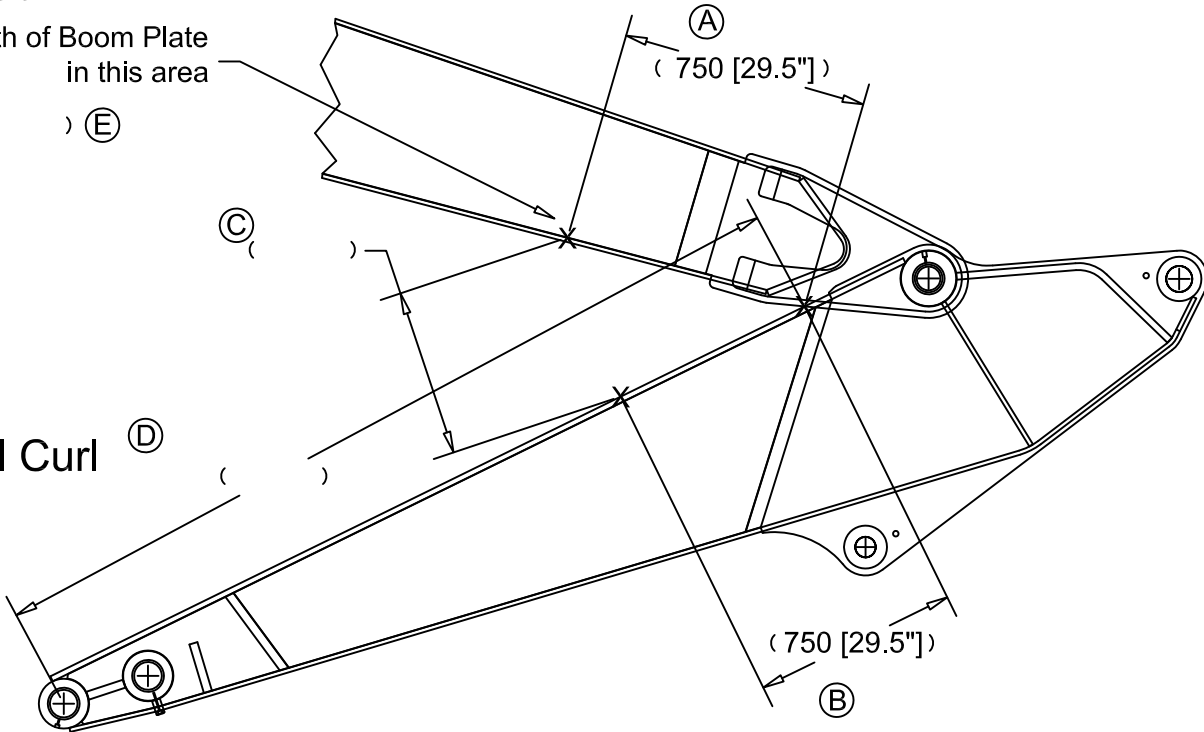

STICK END

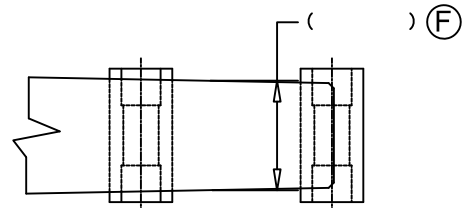
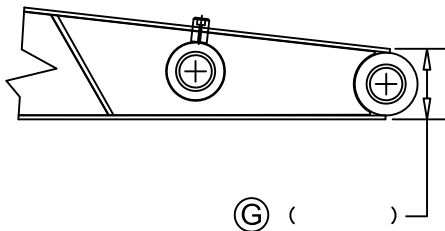

Nye Manufacturing Ltd.

3585 Mavis Rd. Mississauga, ON Canada. L5C 1T7

Tel: 905 897 2311 Fax: 905 897 2312 nyemanufacturing.com



Bucket Take-off Sheet.

Machine Make:	Machine Model:	Bucket Make:
Bucket Width:	Bucket Capacity:	Serial Number:
Customer Name:	Completed by:	Date:

Bucket Details.

Please fill in all brackets clearly. Make allowances for worn teeth.

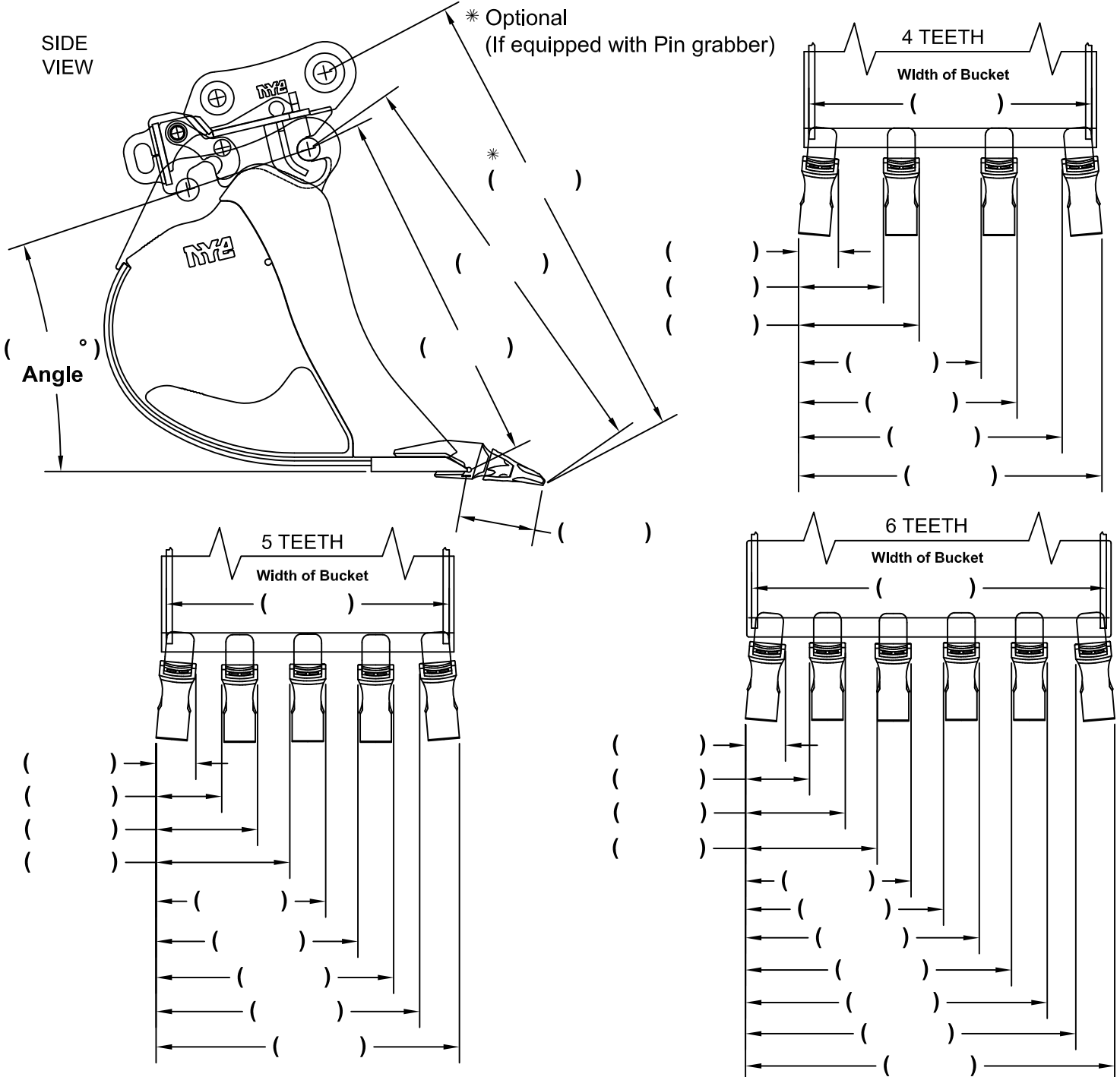

Nye Manufacturing Ltd.

3585 Mavis Rd. Mississauga, ON Canada. L5C 1T7
 Tel: 905 897 2311 Fax: 905 897 2312 nyemanufacturing.com